



## IPI28XXD-30

### Dual Output Series High Reliability DC-DC Converters

#### FEATURES

- High reliability, compact size
- High power density: 31W/in<sup>3</sup>
- Input voltage range: 16V<sub>DC</sub> to 40V<sub>DC</sub>
- Output power: 30W
- Inhibit and synchronization functions
- Fully isolated
- Over-current / short-circuit protection
- Hermetically sealed metal DIP package



#### DESCRIPTION

The IPI28XXD-30 dual output series DC-DC converter is an integrated, hermetically sealed thick-film microcircuit and is a perfect fit for a variety of demanding hi-rel industrial, aerospace and military applications. The output voltage options are  $\pm 12V$  or  $\pm 15V$  with output power rated from 30W. The switching frequency is fixed at 265KHz to minimize noise and includes an internal input filter circuit designed to reduce electro-magnetic interference. The typical input voltage is 28V<sub>DC</sub>, and covers input ranges from 16V<sub>DC</sub> to 40V<sub>DC</sub>. The IPI28XXD-30 series also provides control functions such as synchronization, shut down, and over-current / short-circuit protection.

#### BLOCK DIAGRAM

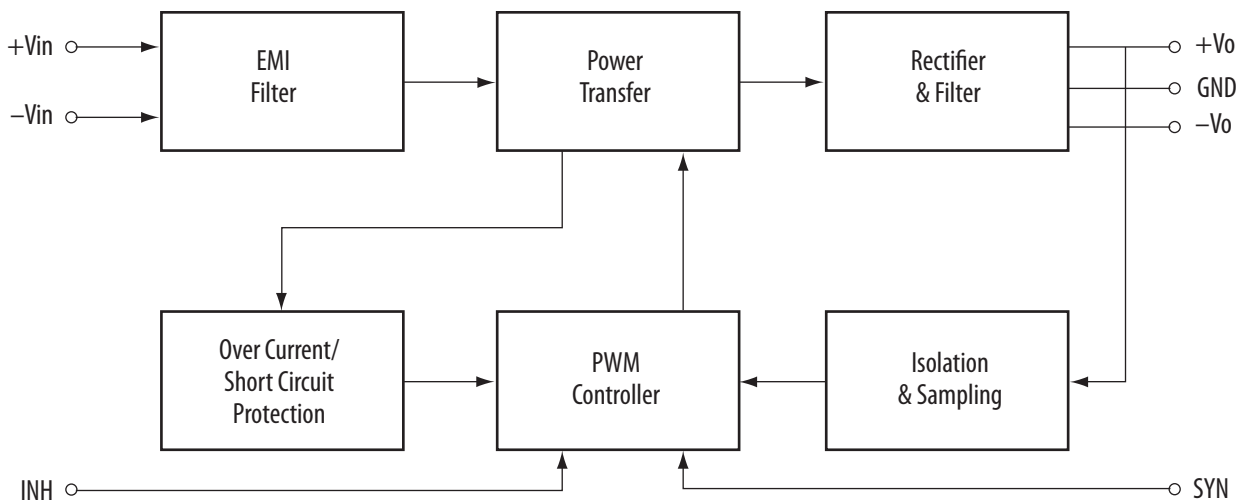

<b>ABSOLUTE MAXIMUM RATINGS</b>	INPUT VOLTAGE:	16V <sub>DC</sub> – 40V <sub>DC</sub>	
	OUTPUT POWER:	30W	
	OPERATING TEMP (T <sub>C</sub> ):	–55°C to +105°C (M)	–40°C to +85°C (E)
	STORAGE TEMP:	–55°C to +125°C	
	PIN SOLDER TEMP (10S):	300°C	

## ELECTRICAL CHARACTERISTICS

PARAMETER	CONDITIONS <sup>5</sup>	IPI2812D-30			IPI2815D-30			UNITS
		MIN	TYP	MAX	MIN	TYP	MAX	
OUTPUT VOLTAGE	+V <sub>o</sub>	11.88	12.00	12.12	14.85	15.00	15.15	V
	–V <sub>o</sub>	11.82	12.00	12.18	14.77	15.00	15.23	
OUTPUT CURRENT	V <sub>IN</sub> =28V <sub>DC</sub> ±I <sub>o</sub>	0	–	1.25	0	–	1.0	A
OUTPUT POWER	V <sub>IN</sub> =28V <sub>DC</sub>	0	–	30	0	–	30	W
OUTPUT RIPPLE VOLTAGE <sup>1</sup>	±V <sub>o</sub> 20MHz T <sub>C</sub> MIN to MAX T <sub>C</sub>	–	30	80	–	25	80	mV <sub>pp</sub>
		–	40	120	–	40	120	
LINE REGULATION	V <sub>IN</sub> = 16V <sub>DC</sub> 40V <sub>DC</sub> +V <sub>o</sub>	–	10	30	–	10	30	mV
	V <sub>IN</sub> = 16V <sub>DC</sub> 40V <sub>DC</sub> –V <sub>o</sub>	–	50	120	–	50	150	
	T <sub>C</sub> MIN to MAX T <sub>C</sub> +V <sub>o</sub>	–	10	50	–	10	50	
	T <sub>C</sub> MIN to MAX T <sub>C</sub> –V <sub>o</sub>	–	50	150	–	50	180	
LOAD REGULATION	NO LOAD TO FULL +V <sub>o</sub>	–	15	50	–	15	50	mV
	NO LOAD TO FULL –V <sub>o</sub>	–	30	120	–	50	150	
	T <sub>C</sub> MIN to MAX T <sub>C</sub> +V <sub>o</sub>	–	15	50	–	15	50	
	T <sub>C</sub> MIN to MAX T <sub>C</sub> –V <sub>o</sub>	–	30	180	–	30	180	
CROSS REGULATION	20%-80% <sup>2</sup>	–	4	8.3	–	3	8	%
	10%-50% <sup>3</sup>	–	4	6	–	4	6	
INPUT VOLTAGE	CONTINUOUS	16	28	40	16	28	40	V <sub>DC</sub>
	50V/50ms	0	–	50	0	–	50	
INPUT CURRENT	NO LOAD	–	50	75	–	50	75	mA
	FULL LOAD	–	1.34	–	–	1.29	–	A
	INHIBITED	–	3	8	–	3	8	mA
INPUT RIPPLE CURRENT <sup>1</sup>	20MHz	–	20	50	–	20	50	mApp
EFFICIENCY		78	81	–	80	83	–	%
SHORT CIRCUIT	DISSIPATION	–	15	–	–	15	–	W
	RECOVERY TIME	–	1.4	5.0	–	1.4	5.0	ms
STEP LOAD RESPONSE	±V <sub>o</sub>	–	±150	±400	–	±200	±400	mV
STEP LOAD RECOVERY <sup>4</sup>	50%-100%-50%	–	100	200	–	100	200	µs
STEP LINE RESPONSE	±V <sub>o</sub> OVERSHOOT RECOVERY TIME <sup>4</sup>	–	±200	±400	–	±400	±500	mV
		–	–	300	–	–	300	µs
START-UP	DELAY	–	1.4	5	–	1.4	5	ms
	FULL LOAD OVERSHOOT	–	0	120	–	0	150	mVpk
	NO LOAD OVERSHOOT	–	120	600	–	150	750	
INSULATION RESISTANCE	≥100MΩ @ 500V <sub>DC</sub> (input-output; any pins to case)							

## NOTES

- Using tip and barrel measurement.
- Pout 20%; +Pout 20%-80%
- Pout 10%; +Pout 10%-50%
- Recovery time is measured from application of the transient to the point at which V<sub>out</sub> is within 1% of final value.
- Unless otherwise specified, T<sub>A</sub> = 25°C, 28V<sub>DC</sub> V<sub>in</sub>, 100% load

## TYPICAL PERFORMANCE CURVES

**IPI2815D-30 Output Ripple Voltage**

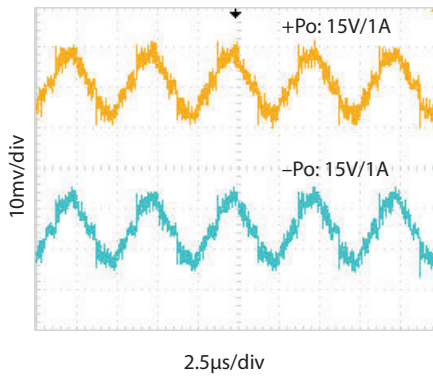

**IPI2815D-30 Start-Up**

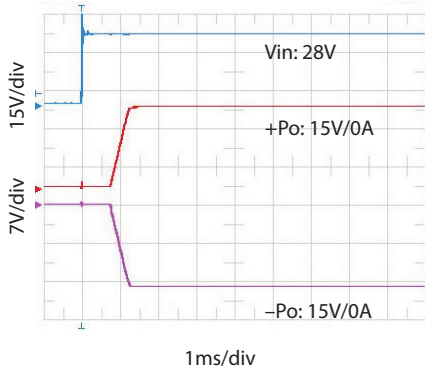

**Efficiency vs. Input Voltage**

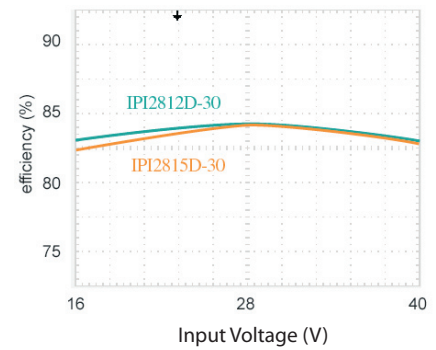

**IPI2815D-30 Load Step 50% - 100% - 50%**

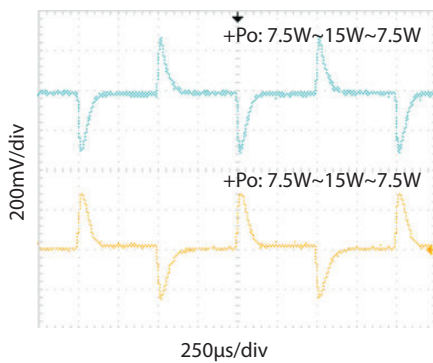

**Efficiency vs. Output Power**

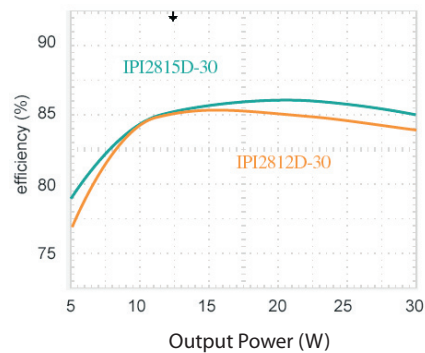

## APPLICATION NOTES

### Inhibit Function

The INH pin is used to control the on/off inhibit function. A connection to Pin 2 is not necessary for normal operation of the converter. Shut down may be implemented by simply pulling Pin 2 below 0.3V referenced to common input.

### Over-Current / Short-Circuit Protection

The IPI28XXD-30 series of DC-DC converters feature internal over-current / short-circuit protection. When operating under a load fault condition, the converter will automatically activate the over-current / short-circuit protection feature and restore the converter to normal operating condition when the load fault is removed. It is suggested that the duration of the over-current / short-circuit be less than 10s, and the case temperature lower than 105°C, or the module will shut down.

### Ripple Voltage Suppress

If the output voltage ripple needs to be reduced for a particular application, adding a high quality 50V / 10µF film or ceramic filter capacitor between Vo+ and Vo- outputs is recommended.

### Synchronization

The IPI28XXDS-30 series of DC-DC converters allows the designer to match the switching frequency of the converter to the frequency of an external system clock or synchronize several modules by use of the synchronization pin. The frequency range is from 200KHz to 350KHz, the voltage level range is from -0.3V to 10V, and the duty cycle range is from 40% to 60%. Under a master and slave configuration, the master module will deliver ±3mA, and the slave will deliver ±0.5mA maximum.

### REVERSE POLARITY PROTECTION

To avoid damage to the converter caused by reverse input connections, it is advised to connect a diode, in series, with the input pin of the converter, as shown below.

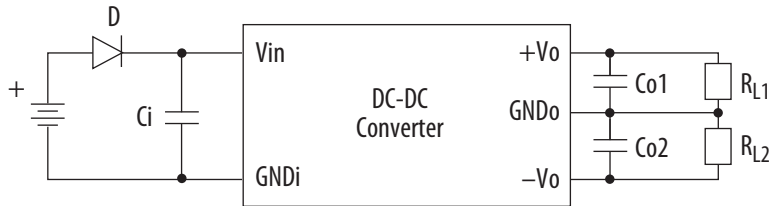

### ORDERING INFORMATION

IP	I	28	12	D	-	30	H	M
Grade: M = Military E = High Reliability								
Package Style: H = H Style Blank = K Style								
Output Power: 30 = 30W								
Number of Outputs: D = Dual								
Output Voltage: 12 = ±12V								
Input Voltage: 28 = 28V								
Hermeticity: I = Hermetically Sealed, Blank = Non-hermetic								
Model Number								

### PRODUCT GRADE

Military (M) and high reliability (E) products are hermetically sealed with a parallel seam welding process. There are two package styles (H and K) for customers to choose from. Please refer to the package outline drawing below and note your preferred package style when ordering.

### MARKING SPECIFICATION

Serial Number: DC 0821 001, example indicates this product has been manufactured in the 21st week of 2008, and the sequence number is 001.

### ENVIRONMENTAL SCREENING

TEST ITEM	METHOD	REQUEST	CONDITION
PRE-CAP INSPECTION	MIL-STD-883 METHOD 2017	100%	-
TEMP-CYCLE	MIL-STD-883 METHOD 1010	100%	-55°C to +125°C (E), 10 Times
CONSTANT ACCELERATION	MIL-STD-883 METHOD 2001	100%	3000 g, Y1, 1 Minute
BURN-IN	MIL-STD-883 METHOD 1015	100%	T <sub>c</sub> +105°C (M) / +85°C (E), 160 Hours
FINAL ELECTRICAL TEST	MIL-PRF-38534	100%	-55°C, +25°C, +105°C (M) -40°C, +25°C, +85°C (E)
HERMETICITY TESTING	MIL-STD-883 METHOD 1014	100%	Fine Leak, Cond. A1 Gross Leak, Cond. C1
FINAL VISUAL INSPECTION	MIL-STD-883 METHOD 2009	100%	-

## MECHANICAL SPECIFICATIONS

WEIGHT:	≤ 63 g
VOLUME:	17.9 cm <sup>3</sup>
ENCAPSULATION:	HERMETICALLY SEALED WELDED SEAM
SHELL MATERIAL:	COLD ROLLED STEEL
PACKAGE STYLES:	H OR K, PLEASE INDICATE PACKAGE STYLE WHEN ORDERING

## PACKAGES

### Package Style H

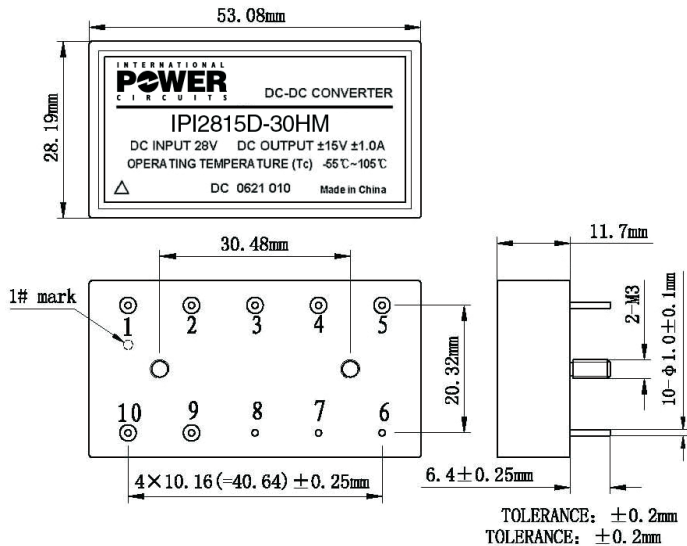

PIN FUNCTIONS (M/E)		PIN
POSITIVE INPUT	+V <sub>IN</sub>	1
INHIBIT	INH	2
POSITIVE OUTPUT	+V <sub>O</sub>	3
OUTPUT COMMON	GND <sub>O</sub>	4
NEGATIVE OUTPUT	-V <sub>O</sub>	5
CASE GROUND	CASE	6
CASE GROUND	CASE	7
CASE GROUND	CASE	8
SYNC	SYN	9
INPUT COMMON	-V <sub>IN</sub>	10

### Package Style K

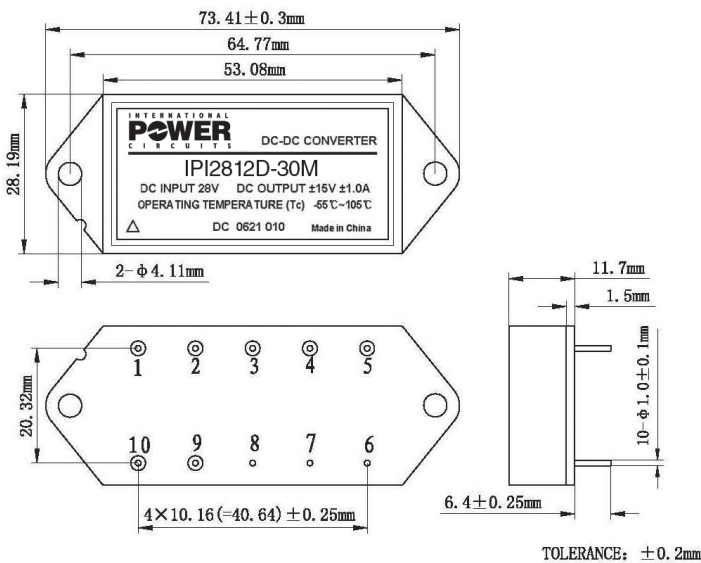

## Notes

1. Please properly connect pins of power module to PCB following instructions of part's specification.
2. To prevent pins of power module from being stressed to cause glass insulators cracked and power module leaked, please install power module with fixed flanges or screws prior to welding pins of power module.
3. The bottom of power module should be stressed to heat sink tightly. If necessary, thermal washers and shockproof gaskets are employed.
4. In any case, bending of pins should be avoided to keep glass insulators from cracking and prevent power module from leaking.